

SEPARATIONS
EXTRACTIONS
WASHING
REACTIONS

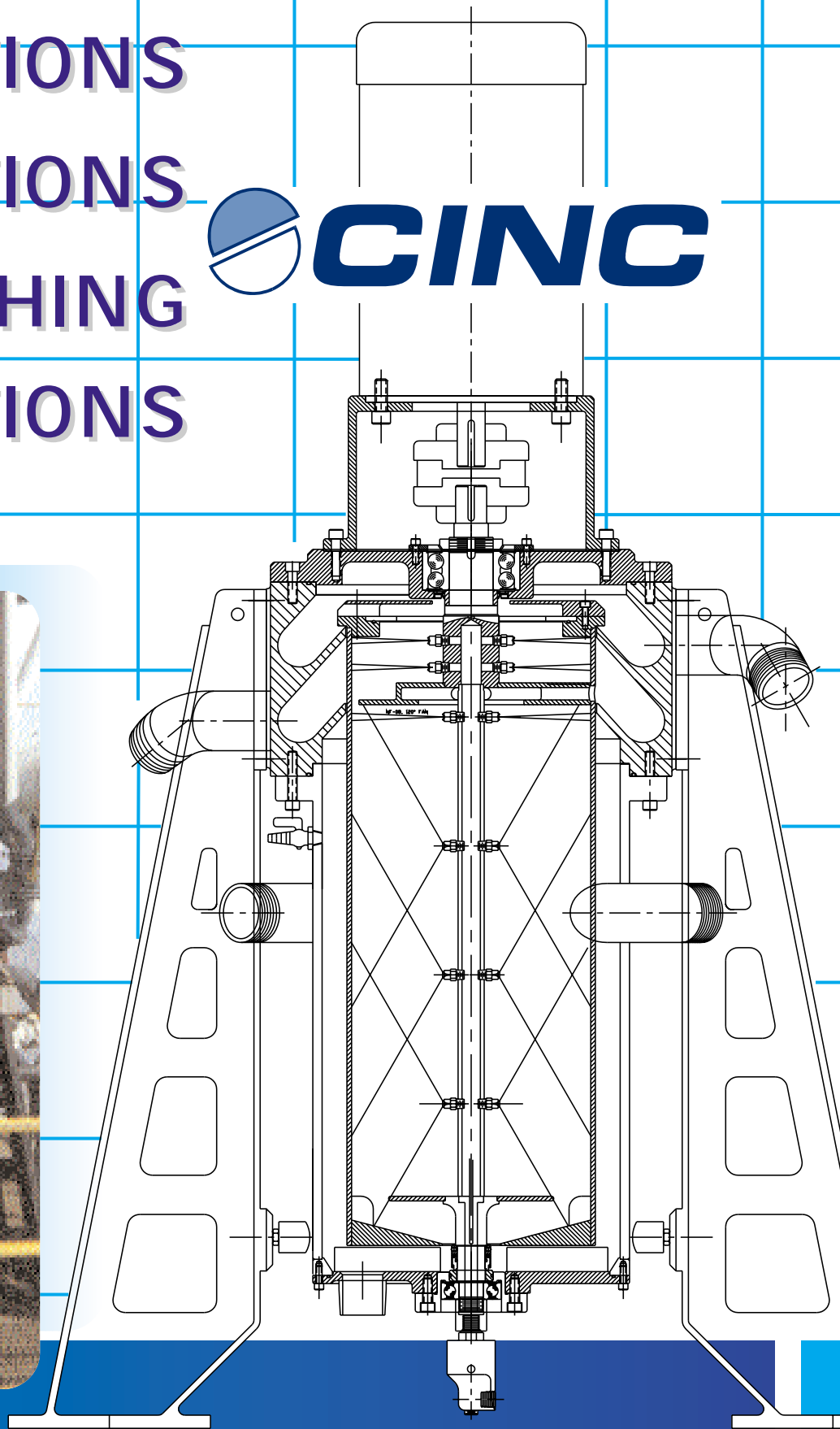

Liquid Centrifugal Processing

PERFORMANCE



CINC's proven, patented technology, coupled with our dedication to liquid processing, leads to our success in a broad range of applications worldwide. Constant research and development by CINC is combined with customer feedback to continually improve and advance our annular centrifugal

contactors. Our design team develops the most dynamic, cost-effective, and reliable liquid-liquid centrifuges available. Ongoing efforts to improve existing designs and exciting new developments like our cGMP line demonstrates CINC's commitment to remain on the cutting edge of centrifuge technology.

Our centrifuges are available in a variety of sizes ranging from R&D and pilot to full production scale units with flowrates ranging from 0.5 gpm to 200 gpm (1.9Lpm to 757Lpm). Process R&D results obtained with a V-2 scale to full capacity models. Multiple units can be employed in parallel or series to handle larger flows or for multi-stage processes.

High separation efficiency from longer residence times at 100-1000 G's provides better process control for improved yields, faster processing, low in-process inventory and minimal waste.



Chemical Industry

- Polymer feed stocks
- Polymer production
- Butadiene and styrene resins
- Organic peroxides
- Azeotrope separations
- Solvent recovery
- Heat transfer fluid recovery



Pharmaceutical Industry

- Antibiotics
- Erythromycin
- Penicillin

Biotech Industry

- rDNA products
- Broth extraction

Food & Nutrition Industry

- Isoflavones
- Edible oils
- Flavors extractions
- Nutraceuticals



EXPERIENCE ■ APPLICATIONS

Environmental Industry

- Oil-spill cleanup
- Groundwater remediation
- Wash water recycling
- Bilge water treatment
- Industrial laundry water de-oiling

Petroleum Industry

- Acid-flowback
- Well completion fluid recovery
- Produced water processing
- Oil-dehydration
- Land and offshore
- FPSO & fixed platform installations

Mining & Metals Recovery Industry

- Solvent extraction of various metals
- Solvent recovery and recycle
- Wastewater separations

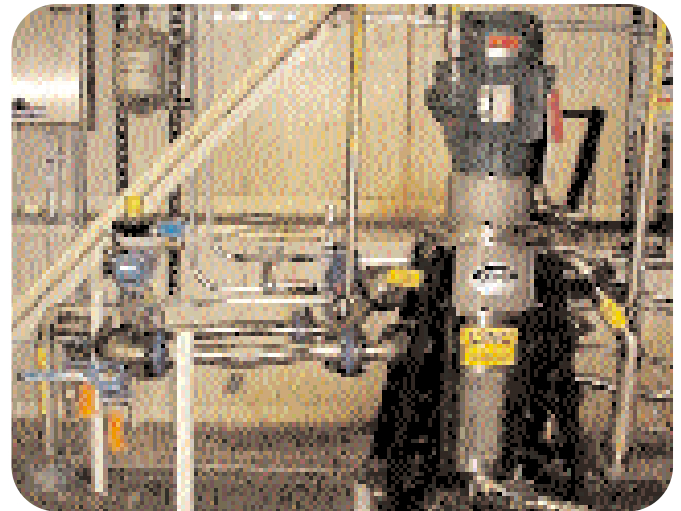

PRINCIPLE OF OPERATION

The CINC liquid-liquid centrifuge operates both as **separator** and **contactor**, which makes it a valuable tool in numerous types of processes. Its unique, patented design provides mixing and separation in a single, compact unit.

The illustration shows a cutaway view of the centrifuge housing, rotor, and related components, together with the liquid flowpath.

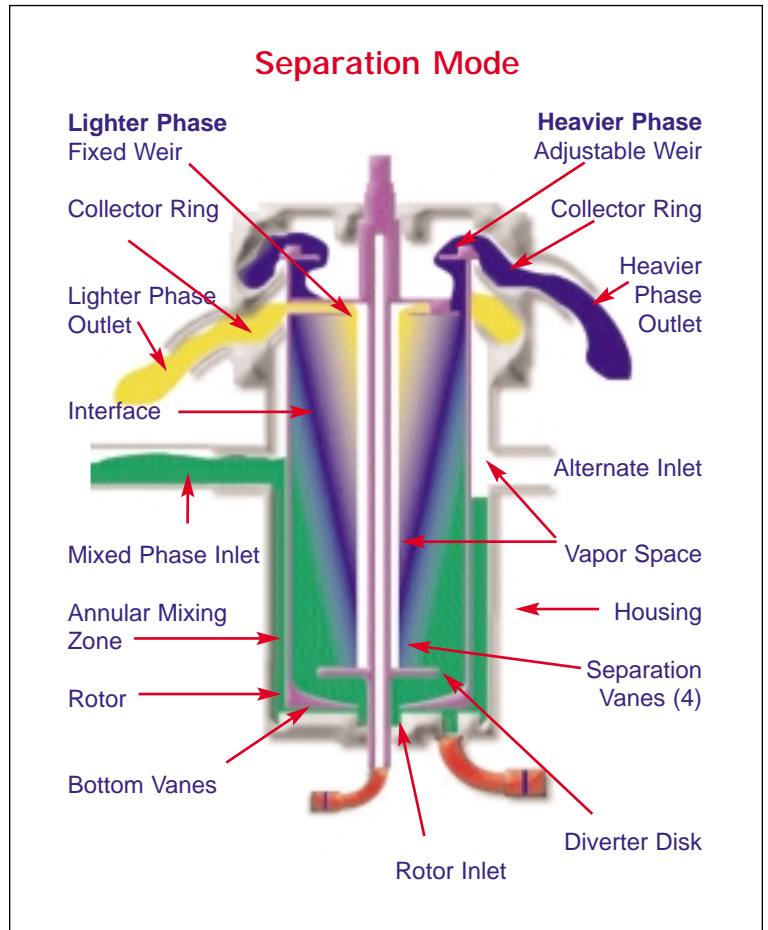
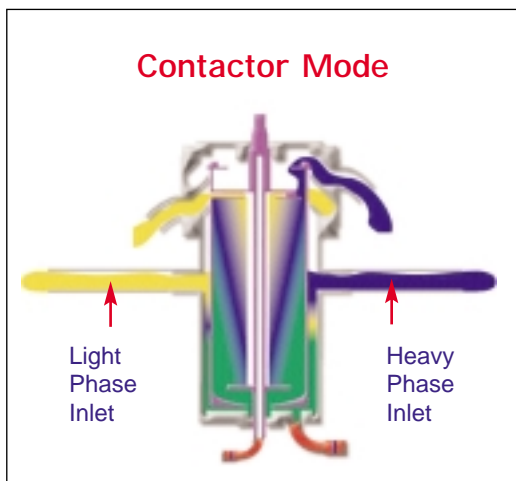

Two immiscible liquids of differing densities are fed to the unit and are rapidly mixed in the annular space between the spinning rotor and the stationary housing. The areas above the liquid levels are vapor space. For separation applications, a low-mix option is employed to reduce liquid shear in the annulus.

The CINC **self-pumping** rotor is divided into four vertical chambers, which are dynamically balanced by the pumped liquids. The mixed phases are rapidly accelerated to rotor speed once trapped in a quadrant, and separation begins as the liquids are displaced upward by continued pumping.

The separating zone extends from the diverter disk to the weir, providing a residence time for the liquid-liquid interface to form and sharpen. In most cases the CINC centrifuge can

process **100% ratio changes** without further adjustment. This capability is due to a large dynamic interface zone that allows it to shift a significant distance without loss of separation efficiency.

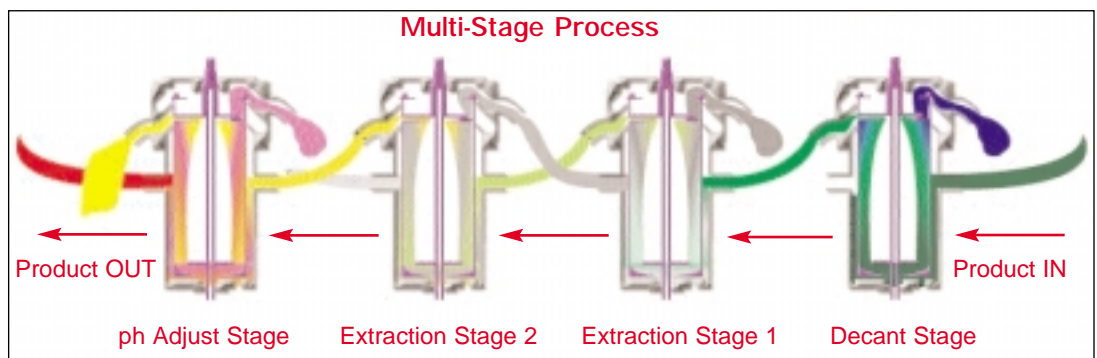

CLEAN-IN-PLACE (CIP) ROTOR

CINC's unique patented Clean-in-Place (CIP) design offers ease of cleaning to remove accumulated solids from the inside wall of the rotor. The CIP design is also ideal for applications requiring thorough washing of the rotor to avoid cross contamination between product batches. A rotary union attached to the tail shaft provides the inlet for the cleaning solution. The process steps for cleaning are quite simple and the entire sequence can be **fully automated**. The total operation is performed in minutes requiring no disassembly of the unit or connection of supply lines. When multiple units are operating in parallel to handle a continuous process, automated sequential cleaning can be used to avoid flow interruptions, without operator attention.

Clean-in-Place rotors are available on all standard CINC centrifuges from the model V-5 to the model V-20. Specialized designs utilizing both CIP and cGMP take-apart technology are also available. If your process contains tramp or small quantities of solids or requires thorough cleaning between batches to insure consistent product purity, our technology is the answer.

Design & Manufacturing

CINC maintains a complete in-house capability for the manufacture of all critical components of our liquid-liquid centrifuges. This ensures that every unit is built to the highest standards of quality and craftsmanship. All units are fully assembled and wet tested prior to shipment.

CINC's experience and capabilities allow for the use of a variety of materials and drive systems to meet the most demanding application requirements. Standard construction is all 316L stainless steel. Hastelloy and other corrosion resistant alloys are also available to fit your process needs. Our direct-drive packages provide quiet operation (**V-20 is 65 dB at 1 Meter**) and can be configured for a variety of electrical requirements. Hydraulic and pneumatic drives are also available.

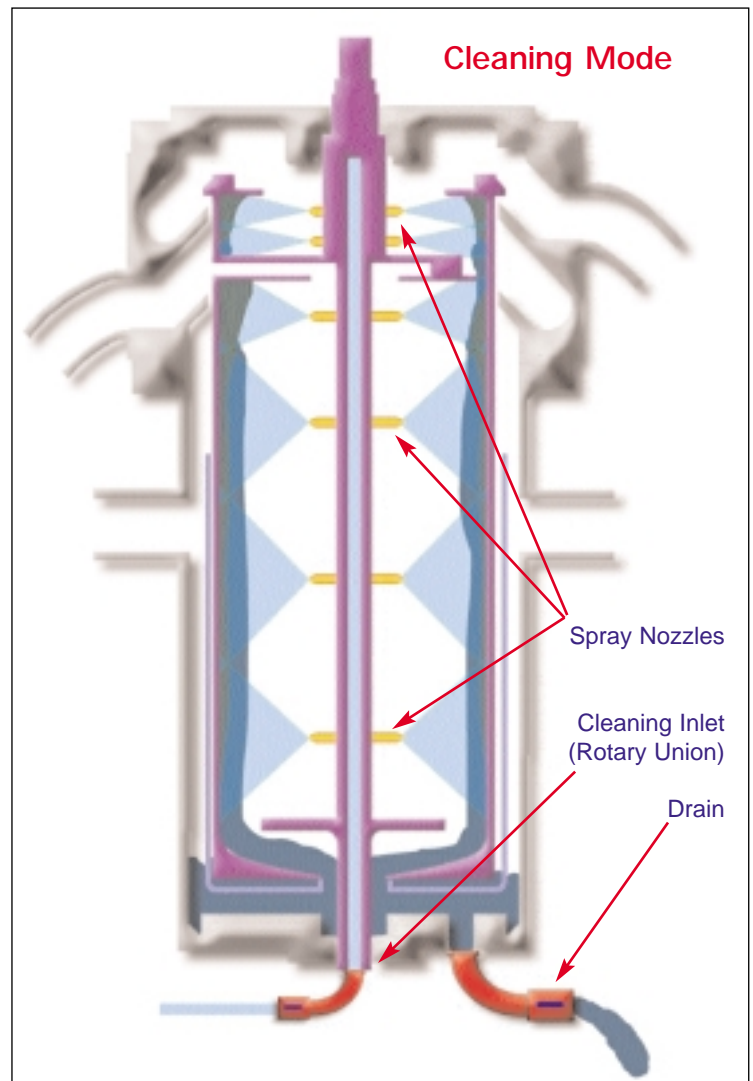

cGMP DESIGN

Chosen by the Editors of *PROCESSING Magazine* as a 1999:

"Breakthrough Product of the Year"

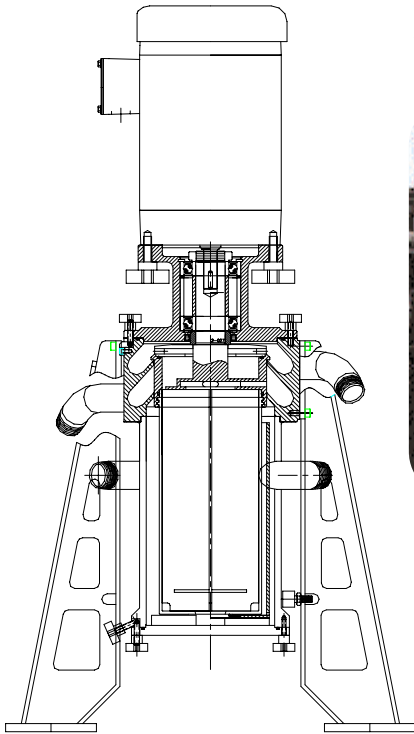

Our new cGMP line enhances the utility of our already versatile centrifuges for use in sterile and FDA approved processes. Inherently simple, the standard CINC design lends itself well to a fully take-apart model that can be easily and rapidly dismantled for thorough cleaning and inspection. Our cGMP units are comprised of a minimum of components and disassembly is accomplished in a series of logical, easy steps.



The cGMP V-5 design eliminates the need for a lower bearing and mechanical seal by utilizing a double upper bearing. This maintains rotor stability while enhancing the simplicity of the unit for disassembly and reducing maintenance.

Our cGMP/CIP V-10 design allows thorough washing of the internal surfaces of the rotor without disassembly, yet can be fully taken apart when inspection is required.

Custom electropolished finishes are available to meet individual plant specifications.



SPECIFICATIONS

Operating Range of CINC Equipment

Model #	0	100	200	300	400	500	600
Model V-02	[Progressive bar from 0 to 600]						
Model V-05	[Progressive bar from 0 to 600]						
Model V-10	[Progressive bar from 0 to 600]						
Model V-16	[Progressive bar from 0 to 600]						
Model V-20	[Progressive bar from 0 to 600]						
Model V-36	[Progressive bar from 0 to 600]						

Unit Specifications

Model	V-02	V-05	V-10	V-16	V-20	V-36
Rotor Size	2.00" 5.08 cm	5.00" 12.7 cm	10.00" 25.4 cm	16.00" 40.6 cm	20.00" 50.8 cm	36.00" 91.4 cm
Throughput	.5 gpm 1.9 lpm	6 gpm 22.7 lpm	30 gpm 113.5 lpm	90 gpm 340.6 lpm	200 gpm 757 lpm	600 gpm 2271 lpm
Footprint	9" x 9" 22.8 x 22.8 cm	1' x 1' 30.5 x 30.5 cm	2' x 2' 70 x 70 cm	3' x 3' 91.4 x 91.4 cm	4' x 4' 122 x 122 cm	9' x 10.3' 274 x 315 cm
Height	25" 63.5 cm	3' 91.4 cm	5' 152.4 cm	6.5' 195.6 cm	8.5' 256.5 cm	9' 274.3 cm
Fittings	3/8" x 3/8"	1" x 1"	2" x 2"	3" x 4"	4" x 4"	6" x 6"
Weight	25 lbs 11.3 kg	150 lbs 68 kg	750 lbs 340 kg	3,000 lbs 1361 kg	4,500 lbs 2041 kg	12,000 lbs 5443 kg
Horsepower	1/8 Hp	2 Hp	7.5 Hp	30 Hp	60 Hp	100 Hp

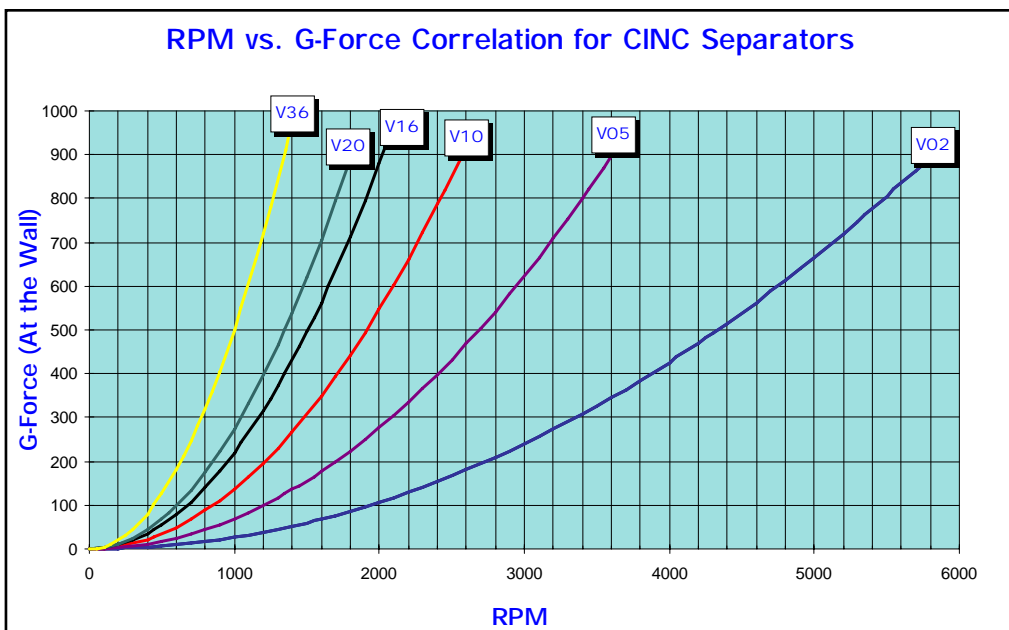

Company Purpose

We provide state-of-the-art liquid-liquid centrifugal processing equipment to industry. We provide the highest level of service, engineering and quality to our customers. Creative solutions will be driven by innovative designs that meet or exceed the expectations of our clients. We will remain a leader in liquid-liquid centrifugal technology that creates exceptional value and provides improvements to the environment in every process served.



Customer Support

CINC's staff of liquid processing experts is always ready to offer responsive customer support. They are available to assist you in obtaining the best possible combination of cost and performance.

